

CONCEPTLASER

M2 cusing Metal laser melting system

Machine technology for safe processing of aluminum and titanium alloys.



Standard design available in grey, optional in white.



M2 cusing TECHNICAL DATA

Build envelope LaserCUSING®	250 x 250 x 280 mm ³ (x, y, z)	
Layer thickness LaserCUSING®	20 - 80 µm	
Production speed LaserCUSING®	2 - 20 cm ³ /h (depending on material / laser power)	
Laser system	Fibre laser 200 W (cw), optional 400 W (cw)	
Scanning speed	7 m/s, 4,5 m/s for variable focus move	
Focus diameter	50 µm, optional variable focus move (50 µm – 500 µm)	
Reference clamping system (optional)	EROWA, System 3R / others on request	
Connected loads	Max. power consumption 7.4 kW Power supply 3/N/PE AC 400 V, 32 A, compressed air 5 bar 2 gas connections provided N ₂ generator external (optional)	
Inert gas supply	< 1 m ³ /h	
Inert gas consumption	integrated, with a 20 m ² filter surface	
Filtering system	2542 x 1818 x 1987 mm ³ (W x D x H)	
Dimensions	approx. 2.300 kg	
Weight	15 - 35°C	
Operating conditions		
LaserCUSING® materials	CL 20ES	Stainless steel (1.4404)
	CL 31AL	Aluminium alloy (AlSi10Mg)
	CL 41TI ELI	Titanium alloy (TiAl64V ELI)
	CL 42TI	Pure titanium Grade 2
	CL 50WS	Hot-work steel (1.2709)
	CL 91RW	Stainless hot-work steel
	CL 92PH	Precipitation hardening stainless steel (17-4 PH)
	CL 100NB	Nickel-based alloy (Inconel 718)
	CL 101NB*	Nickel-based alloy (Inconel 625)*
	CL 110CoCr*	Cobalt-chromium alloy (F75)*
	remanium® star CL	Cobalt-chromium alloy (by Dentaurum)
	rematitan® CL	Titanium alloy (by Dentaurum)

*The material is currently being prepared. Other materials on request.

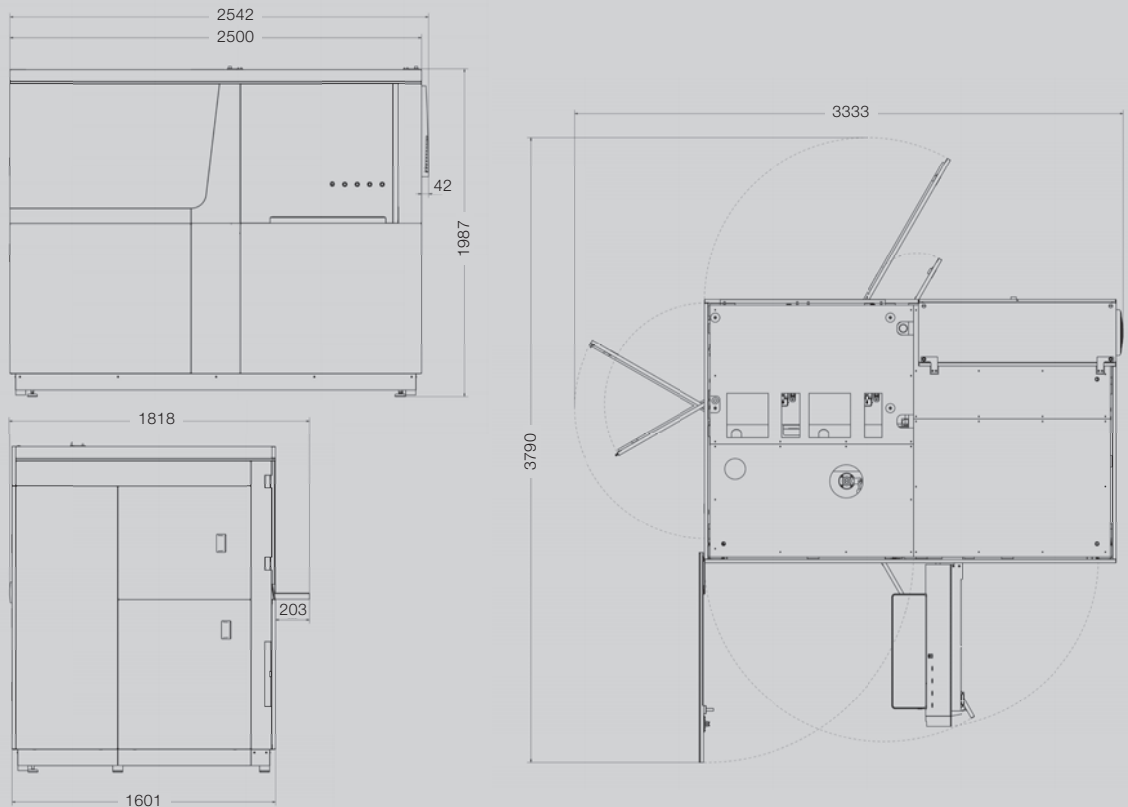

Concept Laser GmbH

An der Zeil 8
 D 96215 Lichtenfels

Sales Department

info@concept-laser.de
 T: +49 (0)95 71. 1679 200
 F: +49 (0)95 71. 1679 299